



CITY OF
PALO ALTO
UTILITIES
1007 Elwell Court, Palo Alto, CA 94303
650-566-4500, 650-566-4501

UTILITY SERVICE APPLICATION
PERMANENT SINGLE FAMILY RESIDENTIAL
ELECTRIC, WATER, GAS, AND WASTEWATER FACILITIES INSTALLATION

TO AVOID DELAYS, PLEASE MAKE SURE THIS APPLICATION IS FILLED OUT COMPLETELY AND AS ACCURATE AS POSSIBLE
A separate application and load information is required for each meter requested
Upon completion of review and approval a copy of this form will be sent back to applicants requesting Electric Service.

Project Address (LEGAL ADDRESS INCLUDING SUITE # IF APPLICABLE):	Suite/Unit #:	Building Department Permit Number:	Utilities Department Application Number:
Name of Applicant:		Owner	Tenant
Company Name:		Consultant	Contractor
Address:		Owner's Agent	
Phone:		E-mail:	
City / State / Zip:			

UTILITY SERVICE CONNECTION AND INSTALLATION CHARGES BILLING INFORMATION

The utility connections charges invoice will either be attached to the building permit plans or mailed to the responsible billing party on this service application. Contact Utilities Engineering for a copy of the invoice. It is the customer's responsibility to be aware of this billing and to make prompt payment. **FULL PAYMENT IS REQUIRED PRIOR TO THE SCHEDULING OF ANY WORK OR INSPECTIONS BY THE CITY OF PALO ALTO UTILITIES.**

Name on invoice (1 person only):	Phone:	E-mail:
Address:	City / State / Zip:	

Services Requested and Desired Date of Installation:	Electric _____	Water _____	Gas _____	Wastewater _____
--	----------------	-------------	-----------	------------------

Depending on Utility Service Type Requested, Please Complete Appropriate Portions of this Application

Project Type (check all boxes that apply)	New Service	Addition	Remodel	ADU / Conversion
	Service Upgrade	Service Relocation	Fire Protection/Sprinkler	Pool/Spa
	PV System (Photovoltaic)	EVSE (Electric Vehicle)	ESS (Energy Storage)	All-Electric Conversion
Brief Description of Work				Total building area upon completion: _____ sq-ft

Water, Gas, Electric Service Load Information (INDICATE PEAK OR MAXIMUM RATES OF USE OR FLOW)

Attach adequate Electric Load information verifying National Electric Code Article 220 (Branch Circuit and Feeder Calculations) requirements are met.

WATER LOADS & FIXTURES (PER METER)

GAS (PER METER) & ELECTRIC LOADS (Select Units From List)

DESCRIPTION	QTY	DESCRIPTION	EXISTING	NEW	UNITS
NUMBER OF FULL BATHROOMS		WATER HEATER/TANKLESS			BTUH
NUMBER OF HALF BATHROOMS		POOL/SPA HEATER			BTUH
ADDITIONAL SHOWERS TO A BATHROOM		SPACE HEATING/HEAT PUMP			BTUH
NUMBER OF KITCHENS (1 SINK & 1 DISHWASHER)		COOKING EQUIPMENT			BTUH
NUMBER OF LAUNDRY (1 SINK & 1 WASHING MACHINE)		CLOTHES DRYER			BTUH
NUMBER OF HOSE BIBS		FIRE LOG/FIREPLACE			BTUH
NUMBER OF SINKS/WETBARS (NOT KITCHEN SINK)		AIR CONDITIONING			kVA
TOTAL NUMBER OF DOMESTIC FIXTURE UNITS, IF KNOWN		ELECTRIC VEHICLE CHARGER			kVA
IRRIGATION LANDSCAPE USE MAXIMUM VALVE, IN GPM		PHOTOVOLTAIC/GENERATOR			kVA
FIRE SPRINKLER LOAD IN GPM (GALLONS PER MINUTE):		OTHERS			kVA

BTUH: BTU (British Thermal Unit) PER HOUR

kW: kilowatts (=1000 Watts)

kVA: kilovoltamps (= 1000 Voltamps)

ELECTRIC (Include Single Line Diagram, Load Calcs, and Main Panel Cut Sheets of Proposed installation for 400 amps and up)

SERVICE INFORMATION	EXISTING	REQUESTED
Main Switch Size (Amps)	60 100 200 320 400 600 Other	125 200 225 320 400 Other No Change
Service Type (Choose one)	OVERHEAD UNDERGROUND	OVERHEAD UNDERGROUND
Number of Meters and Location (NOTE: Only one service per parcel)	No. Meters: _____ Location: _____	No. Meters: _____ Location: _____
Applicant's Name:	Applicant's Signature:	Application Date:

SEE NEXT PAGE FOR REMARKS RETURNED FROM CPAU → → → →

NOTES FOR APPLICANT:

Utility Service Applications involving electric utility work will be reviewed and returned to the applicant with comments and approvals via email. Be sure that your application is approved by Electric Engineering before proceeding with your project to avoid any delays or changes. Comments from Engineering back to the applicant will be provided on page 2 of this application and the applicant must comply with City of Palo Alto requirements before final electrical connection is completed by Utilities.

FOR CPAU USE ONLY

1. All work per NEC and CPA Electric Service Requirements and Standards. For more details, visit <http://www.paloalto.gov/ElectricServiceRequirements>
2. Payment of the final invoice must be received by the City of Palo Alto before any work will be scheduled.
3. Call Electric Operations (650) 496-6914 for Service Disconnect and Reconnect, if required.
4. All work must be inspected & approved by Electric Operations Inspection (650) 496-6977 & Building Department (650) 329-2496 prior to connection by Electric Operations Crews.
5. AIC rating is based on the proposed meter location. CPAU must be notified of any changes as this may affect the available short circuit current at the panel and the required AIC rating of the panel.

Additional Sheets are Attached: Yes No

Electric Service Information <i>(CPAU use ONLY)</i>		Service Order Number	
Estimated Demand	kVA	Transformer kVA and Type	
Map Number		Transformer Number(s)	
Fees	\$	Unless otherwise noted below * Standard <u>Min</u> AIC rating for panel ≤ 200 – 10,000 amps Standard <u>Min</u> AIC rating for panel > 200 – 27,300 amps *	
Electric Application Approved by:		Phone #:	Date:

*Alternatively, per CPAU Engineering, the following AIC rating might be used for the requested electric panel:

_____ **A Sym** at _____ **V** with a minimum _____ **ft. service cable length** (assuming that CPAU's standard cables are used)

UTILITY PLAN SUBMITTAL CHECKLIST:

This checklist is intended to provide general guidance and minimum criteria for the design and construction requirements for utility facilities for any development located within the City of Palo Alto. The purpose of this plan submittal checklist is to clarify the minimum information Utilities Engineering requires for the review of the service application.

Utilities Engineering will only review and provide written comments on a completed set of design plans that are submitted for review.

- COMPLETED AND SIGNED UTILITY SERVICE APPLICATION INCLUDING UTILITY DEMANDS FOR THE REQUIRED SERVICES
- FINAL AND LEGAL ADDRESS FOR THE SERVICE OR METER LOCATION. ADU'S MUST HAVE AN ADDRESS TO ESTABLISH SERVICE.
- SITE PLAN SHOWING EXISTING AND PROPOSED UTILITY SERVICES, METER LOCATIONS, BACKFLOWS, CLEANOUT, BACKWATER VALVE ETC.
- EASEMENT REQUIREMENTS
- ARCHITECTURAL PLANS TO REVIEW METER LOCATIONS (ELEVATION PLANS, FLOOR PLANS, WINDOW SCHEDULES)
- ELEVATION PLANS SHOWING GAS/ELECTRIC METERS IN RELATION TO WINDOWS, VENTS, BUILDING EQUIPMENT OR SOURCES OF IGNITION
- PLUMBING, MECHANICAL PLANS INDICATING LOADS AND GAS PIPING DIAGRAM.
- SITE OR PLUMBING PLANS SHOWING THE CITY SEWER CLEAN OUT AND PROPOSED SEWER DISCHARGE CONNECTION. ADU'S ARE INCLUDED
- LANDSCAPING PLANS SHOWING EXISTING AND PROPOSED TREES TO BE PLANTED NEAR UTILITY LINES
- ELECTRICAL PLANS SHOWING UNDERGROUND AND OVERHEAD UTILITIES AND SERVICE POINT OF CONNECTIONS WITH METERS
- LOCATION OF ELECTRICAL MAIN SERVICE PANEL AND SUBPANELS IF RELOCATING THE ELECTRIC SERVICE MORE THAN 10 FEET.
- ELECTRIC SINGLE LINE DIAGRAM, LOAD CALCS, EUSERC AND NEC 230.71 COMPLIANT MAIN PANEL CUT SHEETS OF PROPOSED INSTALLATION (REQUIRED FOR 400 AMPS AND UP REQUESTS)
- FRONT VIEW PHOTOS OF EXISTING GAS AND ELECTRIC METERS (FOR SERVICE UPGRADES)
- ADDITIONAL UTILITY LOADS DETAILS BEYOND THOSE LISTED ON THE APPLICATION
- INTERCONNECTION AGREEMENT FOR NET ENERGY METERING GENERATING FACILITIES: PHOTOVOLTAIC, ENERGY STORAGE PROJECTS

A GUIDE TO THE CITY OF PALO ALTO UTILITIES DEPARTMENT ELECTRIC SERVICE APPLICATION PROCESS

The following procedure is intended to help you understand how your Utility Service Application for an electric service connection at your electric panel is normally processed.

1. Customer presents to **BUILDING DEPARTMENT (BD)** (Development Center - 285 Hamilton Ave.) a completed "UTILITY SERVICE APPLICATION" for Commercial or Residential Electric Service including all service demands plus **SITE and ELEVATION PLANS SHOWING THE ELECTRIC PANEL AND THE PROPOSED SERVICE LOCATION. NO FULL-SET SUBMITTALS PLEASE.** BD forwards the plans and application to UTILITIES ELECTRIC ENGINEERING (UEE) for Utilities review and approval.
2. UEE reviews plans and application. **INCOMPLETE APPLICATIONS WILL NOT BE PROCESSED AND WILL BE RETURNED TO THE APPLICANT.** UEE assesses the work required to furnish service to meet customer's needs, as specified in the application, within **45 BUSINESS DAYS.** UEE will either send an invoice for Advance Engineering Fees, to cover cost of preparing project estimate, or for standard connection fees, for simpler projects. **You must have an approved electric application on file in UEE to schedule a disconnect / reconnect request.**
3. For **TEMPORARY ELECTRIC SERVICE APPLICATIONS**, present the "TEMPORARY ELECTRIC SERVICE" application to BD. Application will be approved within 1 BUSINESS DAY and an invoice will be sent to the customer. **TEMPORARY SERVICE WILL BE INSTALLED BY ELECTRIC UTILITY FIELD OPERATIONS WITHIN 1 – 2 BUSINESS DAYS FOLLOWING RECEIPT OF FULL PAYMENT AND PANEL APPROVAL, EVIDENCED BY INSPECTION METER RELEASE TAG.** Customer is responsible for contacting BD for panel inspection.
4. After plans are approved, UEE prepares the utility connection charges (if applicable) for the installation of the service and meter(s). The utility connection charges will either be attached to the Building Permit Plans or mailed to the customer. **It is the customer's responsibility to be aware of this billing and to make prompt payment.** Utility connection charges must be paid prior to the scheduling of any work performed by the City of Palo Alto. **PERMANENT UTILITY SERVICES WILL BE INSTALLED BY ELECTRIC UTILITY FIELD OPERATIONS BETWEEN 30 AND 40 BUSINESS DAYS FOLLOWING RECEIPT OF FULL PAYMENT AND COMPLETION BY ANY WORK REQUIRED OF APPLICANT.**
5. **After the electric panel or TEMP POST/TEMP SERVICE STRUCTURE passes inspection, the BD will "yellow tag" the electric meter** and send an electric meter set release tag to UTILITIES CUSTOMER SERVICE CENTER (SECOND FLOOR - CITY HALL BUILDING) which will establish an account for billing purposes. **Underground Trench inspection must have a "green tag" before final building inspection.** The Utilities Customer Service Center will check that all fees are paid before sending the electric meter installation tag to ELECTRIC OPERATIONS DISPATCH for meter installation. **ELECTRIC METER(S) WILL ONLY BE INSTALLED WITH FINAL INSPECTION TAGS IN PLACE. The Customer is responsible for coordinating ALL inspections with either the Building Department AND / OR Electric Operations Dispatch.**
6. YOUR UTILITY SERVICE IS NOW COMPLETE - THANK YOU FOR YOUR APPLICATION.

The following directory will assist you if you have any questions throughout the installation process.

ASSISTANCE

- **BUILDING DEPARTMENT** (Development Center - 285 Hamilton Ave.)
Development Center General Number 329-2496
- **BUILDING INSPECTION** (Development Center - 285 Hamilton Ave.)
Inspection Scheduling 329-2496
- **UTILITIES ELECTRIC ENGINEERING**
Contact - Electric Engineering, 1007 Elwell Ct. Office 566-4500
- **UTILITIES CUSTOMER SERVICE CENTER** (2nd Floor, City Hall)
Customer Service Representatives 329-2161
- **ELECTRIC OPERATIONS DISPATCH** (Municipal Service Center, MSC)
For Disconnect / Reconnect and Meter Installation 496-6914
- **UNDERGROUND TRENCH INSPECTION** (Municipal Service Center, MSC)
Contact - Inspection Supervisor 496-6977

OVERHEAD ELECTRIC SERVICE CHECKLIST

Dear Palo Alto Resident/Contractor,

The objective of this informational sheet is to help complete your project in a smooth and efficient manner, thus avoiding unnecessary delays, corrections and additional inspections.

Please remember that it is your responsibility to insure that projects conform to Palo Alto Electric Service Requirements. Electric Operations Crews will not connect non-compliant services.

We invite you to visit our website to consult our Electric Service Requirements Manual. Feel free to download it and print it in part or in its entirety. It is advisable to do so at the designing stage of your project. You can find us at: <http://www.paloalto.gov/ElectricServiceRequirements>

Any new or upgraded overhead electric service requires inspection and approval from a Building Department inspector prior to energizing. Electric Operations will connect an electric service only if it was inspected, passed and received a Yellow Sticker of approval by Building Inspection.

Please go over the checklist below before calling to schedule an inspection. Check each item as you verify that your project complies. Keep in mind that this is just an aid to you and in no way or manner excludes other parts of your project that are not listed here from having to meet our standards and to be in compliance with applicable requirements. Also, you'll find a sample of typical service requirements in the back of this page.

Building Permit application

Electric Service application

Pay fees

Call Customer Service for Account set-up & appointment for disconnecting old service

See CPAU Dwg. SR-CN-O-1009 for installation details

Correct placement of electric meter, electric panel and clearances with respect to other utilities. (Gas)

Correct clearances between conductors and structures (see back of page)

Correct lengths of wire for splicing/connecting the service (24" min. extending from weather head)

Call Building Inspections for Final – issues a meter “Set Tag” and Yellow Sticker

Call Electric Operations Dispatch to arrange for service connection

For your convenience, below is a list of telephone numbers to call when in need of additional information or to schedule inspections. All service requests and inspections are completed in the order received. There is no need to call repeatedly.

- Building Department (Inspections)(650) 329 2496
- Electric Meter Shop(650) 496 6978
- Electric Operations Dispatch(650) 496 6914
- Utilities Customer Service(650) 329 2161

(Please make sure to have the “Yellow” Sticker on your inspected service)

PLEASE REMEMBER: Only qualified CPA electric personnel can enter vaults and boxes, connect, disconnect or reconnect electric services, and/or remove/install electric meters. Illegally connected services are subject to prosecution, will be disconnected, and reconnected only after ensuing investigations are completed.

UNDERGROUND ELECTRIC SERVICE CHECKLIST

Dear Palo Alto Resident/Contractor,

The objective of this informational sheet is to help complete your project in a smooth and efficient manner, thus avoiding unnecessary delays, corrections and additional inspections.

Please remember that it is your responsibility to insure that projects conform to Palo Alto Electric Service Requirements. Electric Operations Crews will not connect non-compliant services.

We invite you to visit our website to consult our Electric Service Requirements Manual. Feel free to download it and print it in part or in its entirety. It is advisable to do so at the designing stage of your project. You can find us at: <http://www.paloalto.gov/ElectricServiceRequirements>

Please go over each item of the checklist below to verify that your project complies. Keep in mind that this is just an aid to you and in no way or manner excludes other parts of your project that are not listed here from having to meet our standards and to be in compliance with applicable requirements. Also, you'll find a sample of typical service requirements in the back of this page. Electric Operations Crews will connect an electric service only after it was inspected and received a **green sticker** of approval from Underground Inspection AND a **yellow sticker** of approval from Building Inspection.

Building Permit application

Electric Service application

Pay fees

Call Underground Service Alert (USA -1 800 227 2600) before you dig

Call Customer Service for Account set-up / appt for disconnect old service

See CPAU Dwg SR-CN-U-1010 for installation details

Contact Electric Underground Inspector:

- ✓ 48 hrs+ before digging to confirm routing
- ✓ Correct placement of electric meter, electric panel and correct clearances with respect to other utilities (Gas)
 - a. No more than three 90 degree bends, (270 degrees total) between pull boxes in a conduit run
 - b. Trenches for residential services: 24" cover in non-traffic areas. 30" cover in traffic areas
 - c. For conduit below ground, use schedule 40 or DB-120 PVC only
- ✓ Conduit installation must be approved by CPA Underground Inspector prior to backfilling for Green Sticker.
- ✓ Pulling of appropriate size mandrel throughout the entire conduit system (No blockage test)
- ✓ Pulling of conductors from pull box to service. (Slack at the box= 2 X box length)

Call Building Inspections for Final – issues a meter “Set Tag” and Yellow Sticker

Call Electric Operations Dispatch to arrange service connection

Telephone numbers to call when in need of additional information or to schedule inspections:

(All service requests and inspections are completed in the order received. There is no need to call repeatedly.)

- Building Department (Inspections)(650) 329 2496
- Utility Underground Inspector.....(650) 496 6977
- Electric Meter Shop(650) 496 6978
- Electric Operations Dispatch(650) 496 6914
- Utilities Customer Service.....(650) 329 2161

(Please make sure to have the “Green” and “Yellow” Sticker on your inspected service)

PLEASE REMEMBER: Only qualified CPAU Electric Personnel can enter vaults and boxes, connect, disconnect or reconnect electric services, and/or remove/install electric meters. Illegally connected services are subject to prosecution, will be disconnected, and reconnected only after ensuing investigations are completed.

This document contains a summary of the City of Palo Alto Utilities (CPAU) requirements. The Applicant has the responsibility to ensure that their final design and installation complies with ALL City of Palo Alto standards. CPAU standards are detailed in the Electric Service Requirements manual, available on the internet at: <http://www.paloalto.gov/ElectricServiceRequirements>

SUMMARY OF GENERAL REQUIREMENTS

The Applicant (includes customer, customer's contractor, customer's consultant, developer, or others working on behalf the owner) is responsible for ALL costs associated with the provision of electric service for their project, excluding the material cost of the transformer and electric meter.

- Applicant must provide a completed Utility Service Application, Site Plan and Elevation plan submittal. The site plan will include at a minimum, an outline of the property lines showing streets; an outline of buildings on the property; a proposed meter location; location of pools or spas; identification of any other significant features on the property that will impact either overhead or underground service wires; and a description of work. The elevation shall show the location of the meter and its relation to other utility or building equipment/windows. FULL-SET SUBMITTALS NOT REQUIRED.
- If a project requires preparation of a project design and estimate, CPAU will charge the Applicant a non-refundable Advance Engineering fee prior to the start of engineering design, plan review, and development of the cost estimate. To initiate engineering design, the Applicant must submit payment at Revenue Collections, 1st Floor, City Hall, City of Palo Alto. If the project is cancelled by the Applicant, the fee is forfeited.
- Service upgrades requiring 400 Amperes or larger may require a padmount transformer and Easement grant.

SUMMARY OF TECHNICAL REQUIREMENTS

1. The Applicant will provide and install service cables and conduit from main panel to the CPAU utility pull box or service point (as determined by CPAU).
2. If underground service cables are connecting to an overhead secondary line, the Applicant will install a box at the base of the pole and a 4 inch riser conduit from the box to the pole.
3. The meter location is subject to CPAU's approval.
4. The Property title-holder will retain ownership of underground service lateral conduits and substructures and are fully responsible for any maintenance or replacement, as necessary.
5. The owner/developer will provide, at no charge to CPAU, easements and access to all electrical utility facilities that are located on private property. At a minimum, a draft easement shall be submitted before any service is energized.
6. Sockets with Test Bypass Facilities are required for panels greater than 200A and are not allowed for panels rated 200A or less.

Underground Service from an Underground Electric System

Applicant will install as required:

- Service box as required by CPAU
- Panel, meter socket enclosure, service riser
- Conduit from panel to utility service box
- Service cable from panel to utility service point

CPAU will install as required:

- Transformer
- Meter
- Connectors at utility service point

CPAU will own and maintain:

Meter, service cable, transformer, service box

Property title-holder will own and maintain:

Panel, meter socket, service riser and conduit

Underground Service from an Overhead Electric System

Applicant will install as required:

- Service box at the base of the CPAU pole
- Panel, meter socket enclosure, service riser
- Conduit from panel to utility service box, 4" riser stub, and enough cable to reach from the meter to the secondary level on the service pole via the service box, including excess cable in the box equal to twice the length of the box.

Panel, meter socket, service riser and conduit

CPAU will install as required:

- Transformer
- Customer provided cable up CPAU utility pole and cover
- Meter
- Connectors at utility service point

CPAU will own and maintain:

Meter, service cable, transformer, service box

Property title-holder will own and maintain:

Overhead Service from an Overhead Electric System

Applicant/Property title-holder will install, own, and maintain, as required:

- Panel and meter socket enclosure
- Service Entrance riser and cable
- Weatherhead and insulated service drop attachment

CPAU will install as required:

- Transformer
- Service drop wire (maximum length 100 feet)
- Meter
- Connectors at weather head

Other than the work I am proposing for my building, is there anything else I am required to install?

You are responsible for installing all substructures (boxes, conduits, etc.) and service cable as determined to be required by CPAU to provide electric service.

Can you recommend a Electrical Contractor?

Unfortunately, CPAU is unable to recommend one private contractor over another.

Where do I submit by Utility Service Application and plans?

Utilities has a representative at the City of Palo Alto Development Center, 285 Hamilton Avenue, who can accept your application or answer questions about your project or the process. If necessary, a time can be set up to meet with staff in Engineering to discuss details of your project.

Is Electric Engineering located at the Development Center downtown?

No, Electric Engineering is located at 1007 Elwell Court off of East Bayshore Road near San Antonio exit off Highway 101. Our hours are Monday through Friday, 9:00 am to 4:00 pm.

I am preparing to submit plans for a permit on a new Commercial Development, but before I do, I would like to discuss what can be expected to provide electric service?

CPAU would be more than willing to meet to do a preliminary review of your electric service needs. We can layout your service options and determine a service location relevant to the available source. We can provide a clear understanding of the utilities standards and policies regarding your service request. A Utilities representative is available at the Development Center for consultation.

I now live in the main house and I have a rental cottage located at the rear of my property, I would like to have a separate meter for the cottage, can that be done?

Our rules only allow one service per lot. To meter the cottage you will need to hire a licensed electrician to change out your existing single meter panel with a dual meter panel. You will also need to contact our customer service department to set up an account for the new meter.

I have lines installed on poles that run behind my house. Can I get them placed underground?

You would be responsible for all costs associated with this work. This includes, but is not limited to, the cost for undergrounding the lines for all utilities (electric, phone, CATV) on the pole, undergrounding the services of any customer affected with this request, and the cost of any easements, permits, and inspections, required for this work.

BUILDING ELEVATION

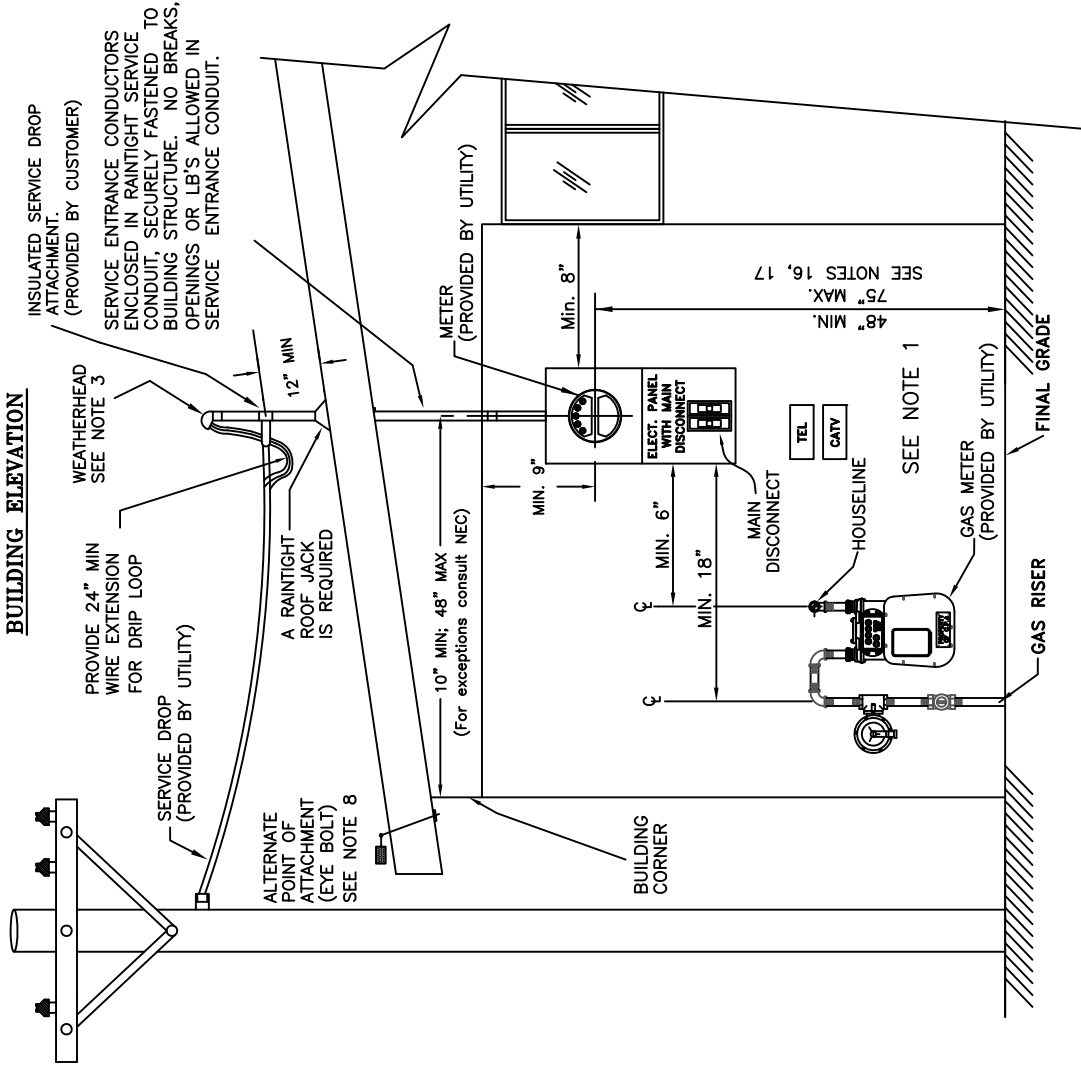

RECOMMENDED SERVICE ENTRANCE CONDUCTOR

Service Voltage (Volts)	Main Service (Amps)	Customer's Minimum Conduit Size	Recommended Conductor Size	
			AL	CU
120/240	100/125	1 1/4" - 2"	1/0	2
1-phase	200	2"	4/0	2/0
3 wire	400 *	4"	750	500
120/208	200	2"	4/0	2/0
1-phase	200	2"	4/0	2/0
3 wire				

* Note: Class 320 (Residential only)

NOTES:

- NO OBSTRUCTIONS ARE PERMITTED WITHIN THE AREA AROUND THE METER, SEE DWG SR-MT-E-1012 FOR DETAILS.
- MAINTAIN A 30" WIDE X 36" DEEP CLEAR AND LEVEL WORKING SPACE IN FRONT OF THE ELECTRIC METER
- THE WEATHERHEAD SHALL BE LOCATED NO MORE THAN 24" FROM THE SERVICE ATTACHMENT POINT AND BETWEEN 18" AND 48" ABOVE THE ROOF, 24" TO 30" RECOMMENDED. IF THE PERISCOPE EXTENDS MORE THAN 30" ABOVE THE ROOF IT SHALL BE BRACED AGAINST THE SERVICE CONDUCTOR PULL.
- THE POINT OF ATTACHMENT MAY BE EITHER ON THE BUILDING WALL NEAR THE UTILITY LINE OR ON A PERISCOPE FIXED TO THE BUILDING'S ROOF NOT MORE THAN 18 INCHES BACK OF THE ROOFLINE.
- THE POINT OF ATTACHMENT SHALL BE BETWEEN 12 AND 18 FEET ABOVE GRADE AND SAFELY ACCESSIBLE BY LADDER. WORKING SPACE FOR A LADDER EQUAL TO A DEPTH OF 1/4 THE HEIGHT OF THE LADDER TOP SUPPORT IS REQUIRED.
- BRACING SHALL BE TWO GALVANIZED STEEL BRACES (3/4" RIGID STEEL PIPE OR 1-1/4" X 1-1/4" X 1/8" STEEL ANGLE IRON MINIMUM) SECURELY BOLTED OR LAGGED TO THE FRAMEWORK WITH 3/8" X 3" LAG SCREWS WITH A 90° SPREAD AND SECURED TO THE PERISCOPE NO MORE THAN 6" BELOW THE SERVICE POINT OF ATTACHMENT.
- ROOF CLEARANCES FOR THE SERVICE DROP MUST MEET THE REQUIREMENTS OF CEC ARTICLE 230.24.
- ONLY ELECTRICAL FACILITIES MAY BE ATTACHED TO THE ELECTRICAL WEATHERHEAD.
- ONLY THREADED PIPE COUPLINGS ARE ALLOWED (NO COMPRESSION COUPLINGS) AND BRACING IS REQUIRED BOTH ABOVE AND BELOW THE COUPLING.
- METER SOCKET CLEARANCE FROM THE GROUND SHALL BE MEASURED FROM THE FINAL GRADE
- WHERE LOAD REQUIRES HEAVY SERVICE DROP CONDUCTORS, THE SERVICE DROP WILL BE 3 SINGLE CONDUCTORS INSTEAD OF CABLE AND 3 EYEBOLTS OR INSULATED CLEVICES WILL BE REQUIRED.
- METER MOUNTING DEVICE SHALL HAVE A MAIN DISCONNECT IN THE SAME CABINET. FOR MORE DETAILED INFORMATION CONSULT CPA ELECTRIC SERVICE REQUIREMENTS MANUAL.
- UNLESS OTHERWISE NOTED, ALL SERVICE FACILITIES ARE THE RESPONSIBILITY OF THE CUSTOMER.
- SERVICE ENTRANCE CONDUIT AND CABLE MUST MEET CEC REQUIREMENTS. PER CEC ARTICLE 404.8(A) THE HIGHEST POINT OF THE BREAKER HANDLE CANNOT BE MORE THAN 79" ABOVE GRADE/FLOOR. SEE CPAU ENG STD DWG SR-MT-3-1035 FOR METER DETAILS ON METER INSTALLATIONS IN DRIVEWAYS.

APPROVED 12/2006

Approved by Engineer
 Checked by Designer
 Drawn by Drafter
 PEV

ENGINEERING STANDARD
TYPICAL OVERHEAD SERVICE INSTALLATION
CITY OF PALO ALTO CALIFORNIA

5	3/16	REV NOTES, ADDED 16,17	TT
4	6/13	REVISED NOTES	TT
3	8/08	REVISED	TT
2	12/06	REVISED	TOPETE
1	9/99	REVISED	FINCH
REV	DATE	DESCRIPTION	APPR
NTS		SR-CN-0-1009	1 OF 1
SCALE		STANDARD NO.	SHEET NO.

MATERIALS:

1. METER MOUNTING DEVICE WITH MAIN DISCONNECT BUILT INTO THE SAME CABINET.
2. UNDERGROUND SERVICE ENTRANCE CONDUIT SHALL BE CONTINUOUS; NO BREAKS, OPENINGS, OR LB'S ARE ALLOWED. CONDUIT SHALL BE GALVANIZED RIGID STEEL OR PVC SCH 40.
3. UNDERGROUND CONDUIT SHALL BE PVC SCHEDULE 40, TYPE DB-120, OR HOT DIPPED GALVANIZED RIGID STEEL.
4. PLASTIC TO STEEL ADAPTOR, IF PLASTIC CONDUIT IS USED FOR 3.
5. MAY REDUCE TO CEC REQUIREMENTS.

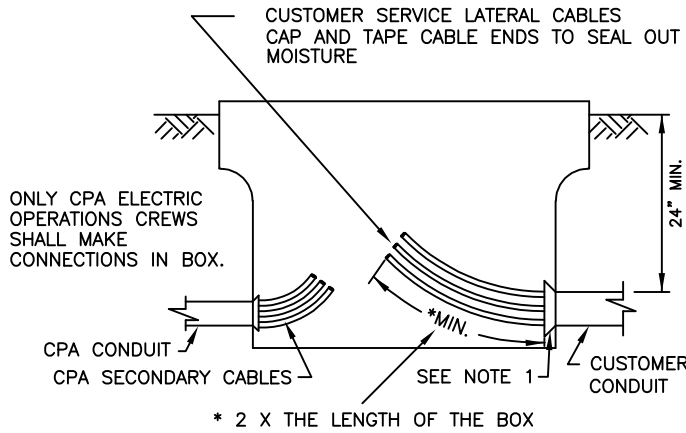
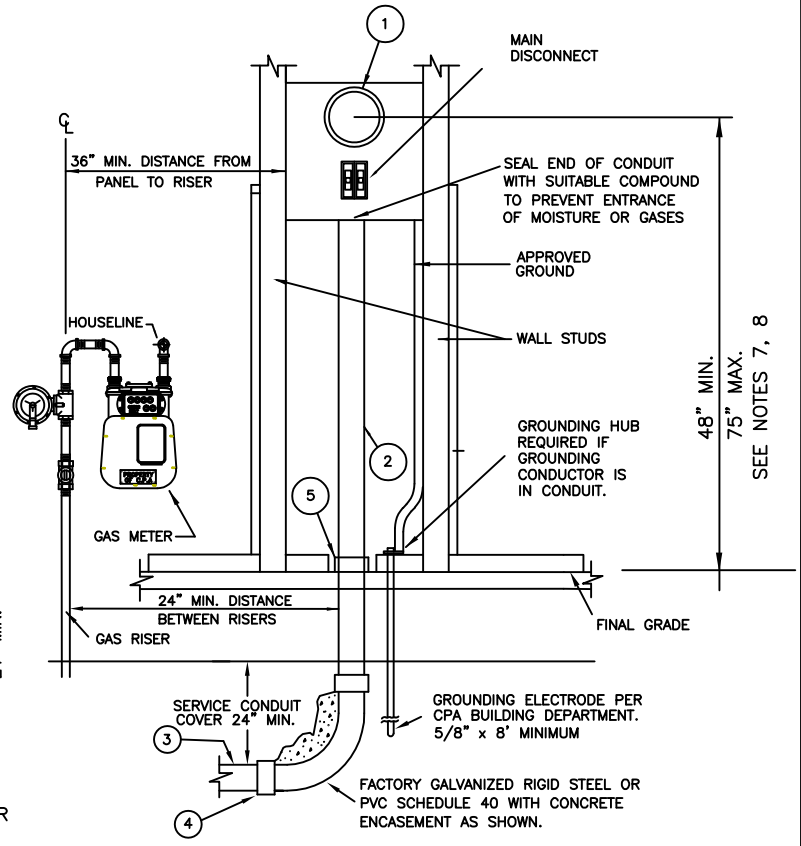

NOTES:

1. STEEL CONDUITS SHALL EXTEND 2" MAX. INTO BOX AND SHALL TERMINATE WITH INSULATED BUSHINGS. PLASTIC CONDUITS SHOULD BE TERMINATED WITH BELL ENDS FLUSH WITH THE WALL OF THE BOX. ALL CONDUIT ENTRANCES SHALL BE GROUTED. SEE CPA STANDARD DRAWING DT-SS-U-1002.
2. IF THE GRADE OF THE TOP OF THE UTILITY SERVICE BOX IS MORE THAN ONE FOOT ABOVE THE END OF THE CONDUIT THAT TERMINATES AT THE BUILDING, BOTH ENDS OF THE SERVICE CONDUIT SHALL BE SEALED BY CUSTOMER WITH APPROVED PLUGS. SUFFICIENT MEASURES SHALL BE PROVIDED TO ENSURE WATER DOES NOT ENTER METER.
3. IF THE GRADE OF THE METER IS BELOW THE GRADE OF THE UTILITY BOX, AN ADDITIONAL BOX MUST BE PLACED IN THE GROUND JUST BEFORE THE METER FOR DETAILS PLEASE CONTACT ELECTRIC ENGINEERING
4. CPAU INSPECTOR MUST BE PRESENT WHEN INSTALLING CONDUIT OR PULLING CABLES INTO CPAU BOX.
5. A SPLICE BOX MAY BE REQUIRED IF ALLOWABLE CABLE PULLING TENSION WILL BE EXCEEDED.

6. SEE CPAU ENG STD DWG SR-MT-E-1012 FOR MINIMUM CLEARANCE REQUIREMENTS AROUND METER PANELS AND SR-MT-E-1035 FOR REQUIREMENTS ON METERS INSTALLED IN DRIVEWAYS.
7. PER CEC ARTICLE 404.8(A) THE HIGHEST POSITION OF THE BREAKER HANDLE MUST BE LESS THAN 79" ABOVE GRADE/FLOOR.
8. PRESS ON LUGS ARE REQUIRED FOR CABLE TERMINATIONS ON SERVICE PANELS 400A OR LARGER, SEE PANEL MANUFACTURER FOR APPROVED LUGS.

SERVICE LATERAL CONDUIT AND CABLE SIZE

Service Voltage (Volts)	Main Service (Amps)	Customer's Minimum Conduit Size	CPAU Approved Conductor Size **	
			AL	CU
120/240 1-phase 3 wire	125	2"	1/0	2
	200	3"	4/0	2/0
	400*	4"	350	4/0
120/208 1-phase 3 wire	200	3"	4/0	2/0

* CLASS 320 (UNDERGROUND RESIDENTIAL ONLY)

** CONDUCTOR SIZE IS PER PHASE AND A FULL SIZE NEUTRAL IS REQUIRED.

6	2-26	UPDATED NOTES & STAFF	KB
5	7-20	REV CLRNC FRM GAS MTR	TT
4	9-16	ADDED 2" CONDUIT EXCEPTION	TT
3	3-16	REV NOTES, TABLE, & DWG	TT
2	5-13	ADDED GAS METER CLEARANCES	TT
1	1-12	REVISED MATERIALS & NOTES	TT
REV	DATE	DESCRIPTION	APPR

APPROVED 02/2026
 Signed by: *Mohammad Paltai*
 2/23/2026
 ENGR. MANAGER

ENGINEERING STANDARD
RESIDENTIAL UNDERGROUND SERVICE REQUIREMENTS

ENGR AK
 UPDATED KB
 CHECKED MF

CITY OF PALO ALTO CALIFORNIA

NTS
 SCALE
 SR-CN-U-1010
 STANDARD NO.
 1 of 1
 SHEET NO.

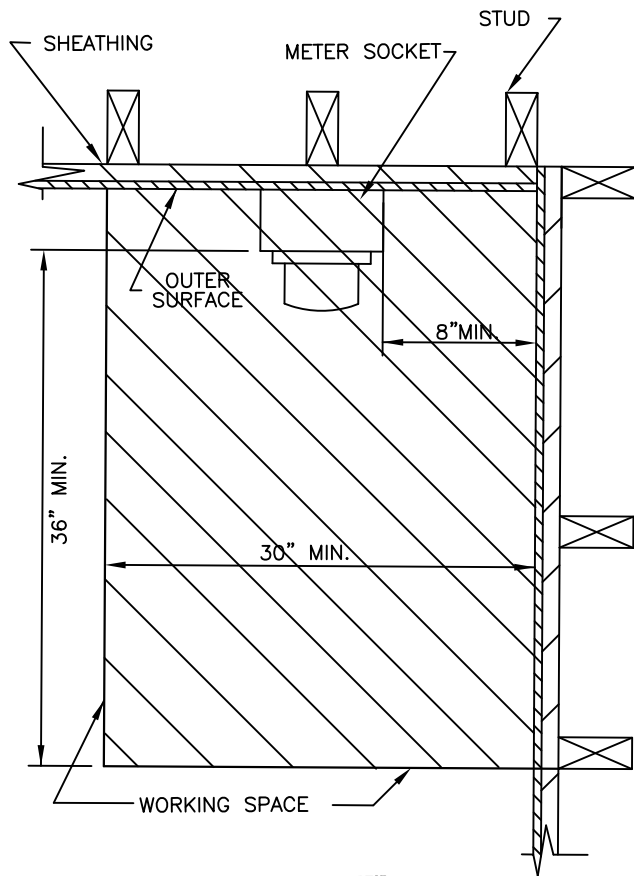

TOP VIEW

NO OBSTRUCTIONS ALLOWED IN SHADED AREA.

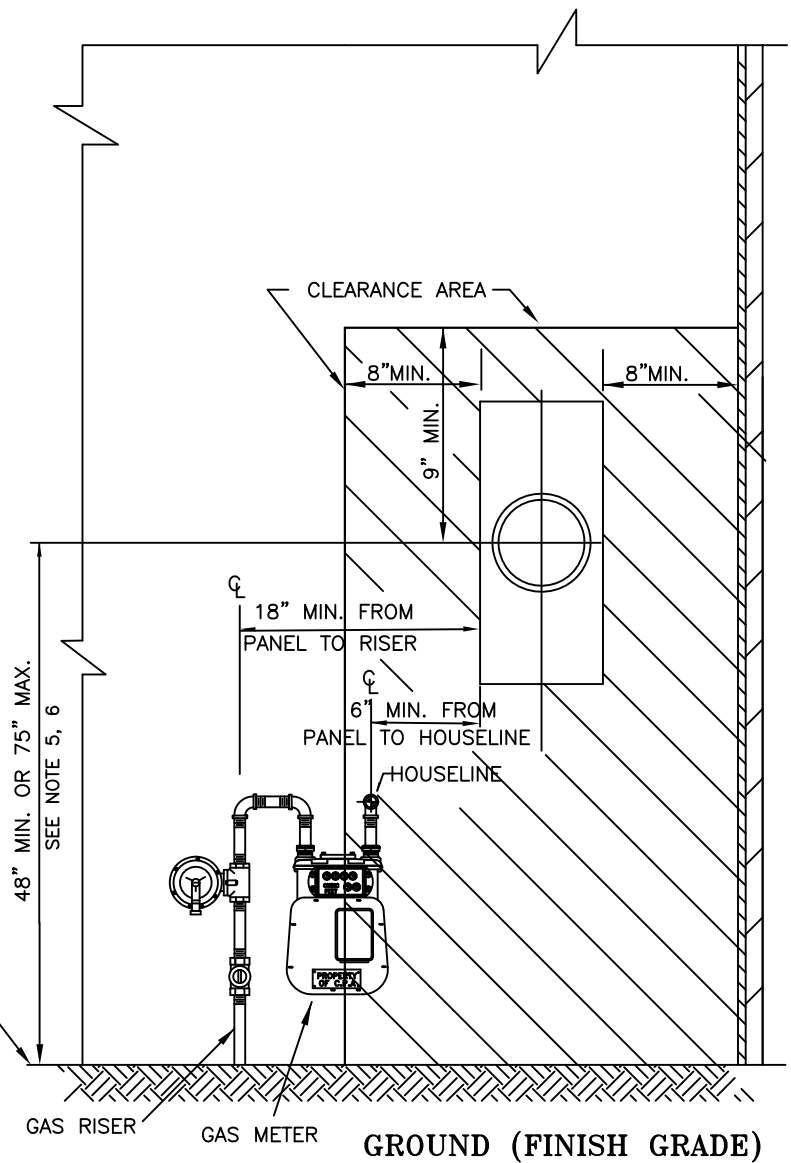

GROUND (FINISH GRADE)

NOTES:

1. THERE MUST BE AN 8 INCH MINIMUM CLEARANCE BETWEEN THE NEAREST EDGE OF THE METER PANEL AND ANY OBSTRUCTION OR WINDOW.
2. SUITABLE WORKING SPACE, AT LEAST 30 INCHES WIDE X 36 INCHES DEEP, SHALL BE PROVIDED IN FRONT OF THE METER SOCKET TO ALLOW FOR INSTALLATION, TESTING AND READING.
3. METERS SHALL BE LOCATED SO THAT THEY WILL NOT BE DAMAGED BY A SWINGING WINDOW OR DOOR.
4. THE WALL SURFACES ON EITHER SIDE OF A DOOR, FOR A DISTANCE EQUAL TO THE WIDTH OF THE DOOR, IS UNACCEPTABLE AS A METER LOCATION.
5. PER CEC ARTICLE 404.8(A) THE HIGHEST POSITION OF THE BREAKER HANDLE MUST BE LESS THAN 79" ABOVE GRADE/FLOOR.
6. SEE CPAU ENG STD SR-MT-E-1035 FOR REQUIREMENTS ON METERS INSTALLED IN DRIVEWAYS.

7	3-16	REVISED NOTES	TT
6	6-14	ADDED GUARD POST NOTE	TT
5	7-13	REVISED GAS METER	TT
4	1-11	REVISED CLEARANCES AND NOTES	TT
3	8-08	REVISED CLEARANCES AND NOTES	JT
2	6-06	REVISED CLEARANCES	TF
REV	DATE	DESCRIPTION	APPR
NTS	SR-MT-E-1012	1 OF 1	
SCALE	STANDARD NO.	SHEET NO.	

APPROVED <u>3/1994</u>	
<i>MOB</i>	
ENGR. MANAGER	
ENGR	PEV
DRAWN	UES/MJ
CHECKED	PEV

ENGINEERING STANDARD
REQUIRED MINIMUM CLEARANCES OF METER SOCKET FROM OBSTRUCTIONS
CITY OF PALO ALTO CALIFORNIA

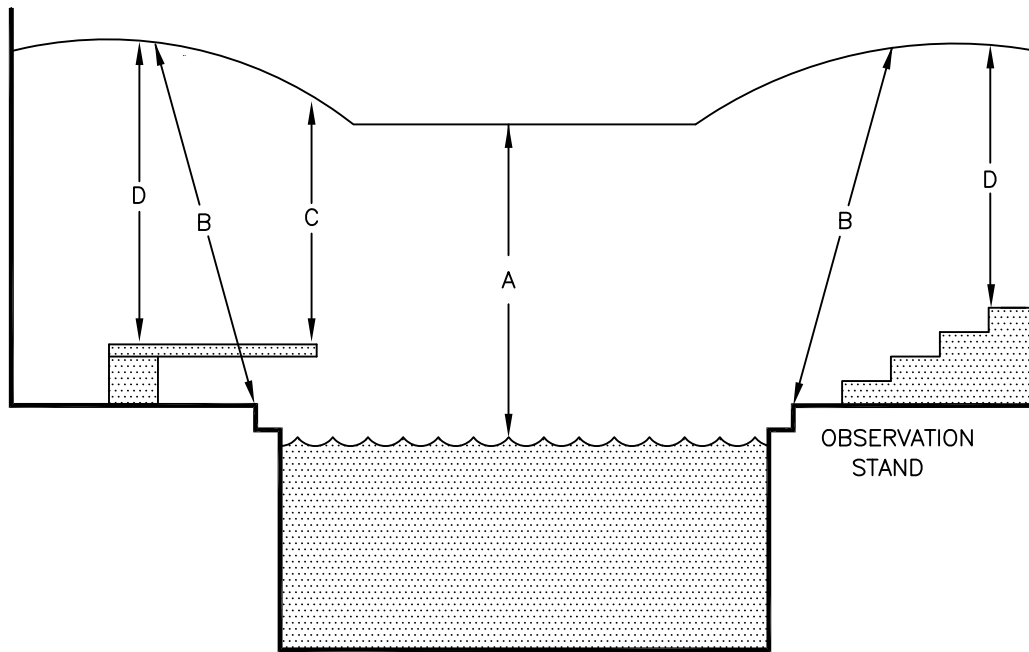

* POOL

NOTES

1. REQUIRED CLEARANCES APPLY TO PUBLIC, COMMERCIALY OPERATED, AND RESIDENTIAL POOLS.

	<u>DIMENSION</u>
A. VERTICAL CLEARANCE FROM HIGHEST WATER LEVEL:	22.5 FEET
B. RADIAL CLEARANCE FROM TOP EDGE OF POOL WALL	22.5 FEET
C. VERTICAL CLEARANCE FROM DIVING BOARD OR PLATFORM THAT IS OVER THE WATER SURFACE OF THE POOL:	14.5 FEET
D. VERTICAL CLEARANCE ABOVE DIVING BOARD OR PLATFORM THAT IS <u>NOT</u> OVER THE WATER SURFACE OF THE POOL:	14.5 FEET

2. HORIZONTAL LIMIT OF CLEARANCES ARE TO THE OUTER EDGE OF ANY ITEMS IDENTIFIED IN ITEMS A TO D, BUT NO LESS THAN 10 FEET OUT FROM THE INSIDE WALL OF POOL.

3. INSTALLATION OF SERVICE DROPS ABOVE SWIMMING POOLS, HOT TUBS, AND SPAS SHALL BE AVOIDED.

4. IF IN THE OPINION OF CITY OF PALO ALTO UTILITIES ENGINEERING AND OPERATIONS PERSONNEL AN OVERHEAD SERVICE INSTALLATION DESIGNED TO MEET THE STIPULATED CLEARANCE REQUIREMENTS CREATES AN UNSAFE WORKING CONDITION FOR UTILITY WORKERS, THE SERVICE WILL BE REQUIRED TO BE UNDERGROUND.

REFERENCE:

CALIFORNIA ELECTRICAL CODE, ARTICLE 680.8

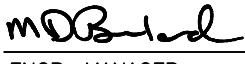
APPROVED <u>3/1994</u>		ENGINEERING STANDARD					
 ENGR. MANAGER		CLEARANCES FROM SERVICE DROPS 0-750 VOLTS SWIMMING POOLS, HOT TUBS & SPAS		2	10/09	REV CLEARANCES/NOTES - CEC	TING
				1	6/99	REVISED	FINCH
				REV	DATE	DESCRIPTION	APPR
ENGR	PEV	CITY OF PALO ALTO CALIFORNIA		NTS	SR-CL-0-1018		1 OF 1
DRAWN	MJ			SCALE			
CHECKED	PEV						

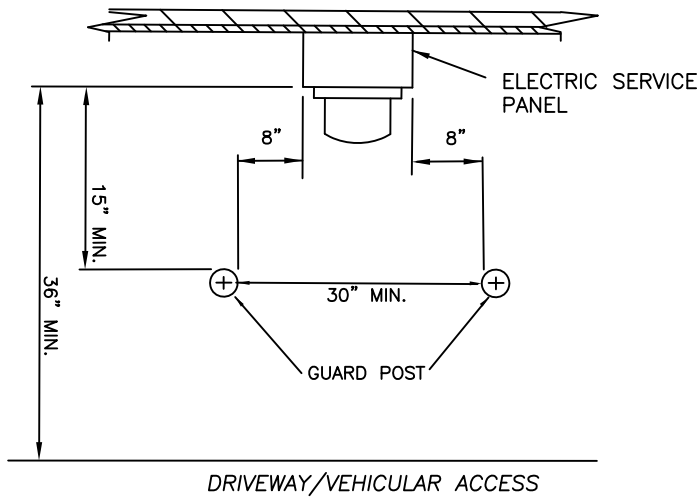

PLAN VIEW

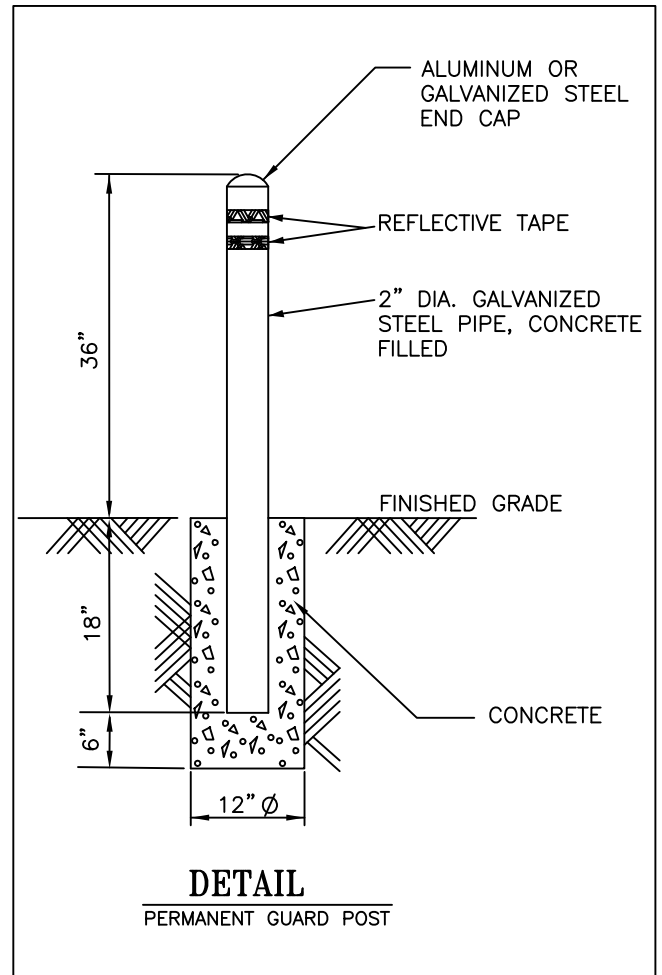

DETAIL
PERMANENT GUARD POST

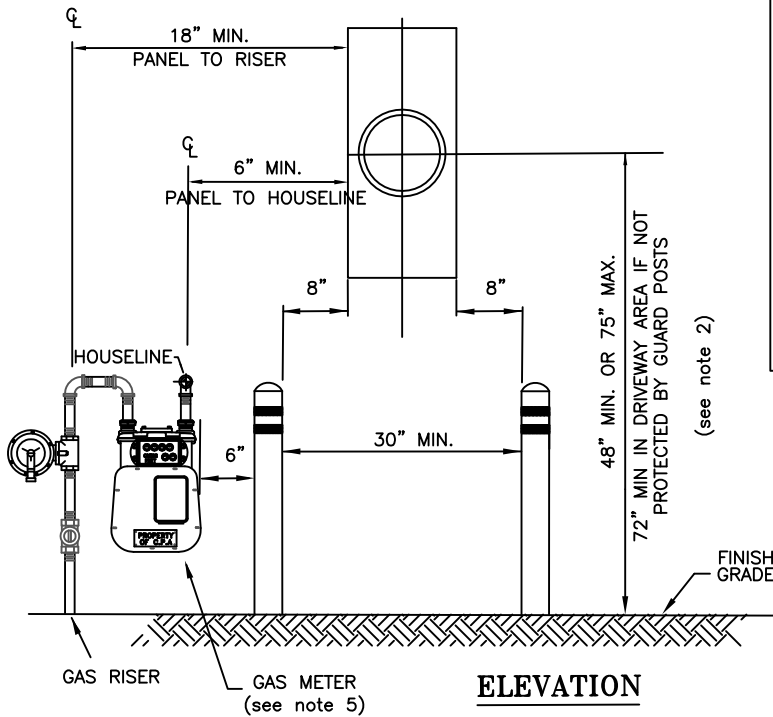

ELEVATION

NOTES:

1. METERS INSTALLED IN LOCATIONS SUSCEPTIBLE TO VEHICULAR DAMAGE SHALL BE PROTECTED BY GUARD POSTS OR INSTALLED AT A SUITABLE HEIGHT TO PREVENT CONTACT.
2. PER CEC ARTICLE 404.8(A), THE HIGHEST POSITION OF THE BREAKER HANDLE MUST NOT BE MORE THAN 79" ABOVE GRADE/FLOOR.
3. THIS STANDARD IS FOR RESIDENTIAL INSTALLATIONS ONLY, NOT FOR MULTIFAMILY DWELLINGS.
4. PERMANENT FIXED POSTS ARE REQUIRED.
5. REFER TO CPAU STD. DWG. WGW-06 FOR GUARD POST REQUIREMENTS AROUND GAS METERS.

APPROVED _____	ENGINEERING STANDARD				
	METER INSTALLATION IN RESIDENTIAL DRIVEWAY	1	3-16	ADDED NOTE 2	TT
		REV	DATE	DESCRIPTION	BY
		NTS	SR-MT-E-1035	1 OF 1	
CHECKED _____	CITY OF PALO ALTO CALIFORNIA	SCALE	STANDARD NO.	SHEET NO.	